

# FOOTPRINT02™

Owner's Manual





## PRODUCT REGISTRATION

Please complete the product registration form for your Barefoot Sound studio monitors to be registered for warranty and product updates.

[CLICK HERE TO REGISTER NOW](#)



## PROTECT YOUR BAREFOOT MONITORS

We will keep the model number and date of purchase of your new Barefoot Sound product on file to help you refer to this information in the event of an insurance claim such as loss or theft.

# FOOTPRINT02™

## Owner's Manual

### CONTENTS

1.0 Description	04
2.0 Warnings! (please read carefully)	05
3.0 Inputs and Controls	06
4.0 Startup	07
5.0 Protection	07
6.0 Signal Flow Diagram	08
7.0 Positioning	09
7.1 Widening the Stereo Field	10
7.2 Cooling	10
8.0 Maintenance	11
8.1 Technical Support and Service	11
9.0 MEME™	12
9.1 MEME Voices	12
9.2 MEME™ Voicing Frequency Responses	13
9.3 MEME™ Voice Selector Connection	13
10.0 Dual-Force™ Technology	14
11.0 Frequency Response	15
11.1 Polar Frequency Response	16
12.0 Specifications	17
13.0 Drawings	18
14.0 Limited Warranty	19
14.1 Warranty Conditions	19
14.2 Obtaining Warranty Service	20
14.3 Post Warranty Repair	20
14.4 Warranty Exclusions	21
14.5 Service Request	21

## 1.0 Description

The Footprint02 is a 3-way active system with 4 drive units housed in sealed enclosures spanning 42 Hz to 45 kHz with low distortion, wide dynamic range and ultra-fast transient response. The 1" ring radiator tweeter is exceptionally detailed and produces very wide dispersion beyond the highest audible frequencies. The 4" midrange is housed in a sealed enclosure for fast transient response. Its ultra-stiff and lightweight aluminum cone moves as a perfect piston well beyond its intended frequency range. The 6.5" side-firing woofers are housed in a sealed enclosure for fast

transient response and feature Barefoot's renowned Dual-Force™ vibration cancelation technology. The net result is incredible transparency and detail across the entire audio spectrum. Barefoot's innovative Multi Emphasis Monitor Emulation™ technology, or MEME™, enables the Footprint02 to emulate the frequency, phase and transient responses, dynamic compression and overall translation characteristics of other classic studio monitors.



## 2.0 Warnings

The Mains power voltage must never exceed 250 VAC. Connecting the power cord to AC power line voltages over 250 VAC will damage the amplifier and may cause the risk of fire. Such damage is NOT covered under warranty.

Rear panel Mains power input layout.



## Please read and follow the safety information below:

- Do not remove the rear amplifier panel. There is a risk of electric shock. No user serviceable parts are inside. Please refer service issues to a qualified technician.
- Do not operate this device with an ungrounded mains power cable or a mains connection that is ungrounded. This may result in personal injury.
- Do not place open flames such as lighted candles on or near this device .
- Do not expose this device to water, rain or high humidity. Do not place objects filled with liquids, such as vases, on or near this device.
- This speaker requires adequate airflow to maintain proper cooling. Do not obstruct airflow around the speaker.
- Do not operate this device in ambient temperatures above 30°C (85°F). Over-temperature may cause device failure.

**Caution!** This speaker is capable of producing sound pressure levels in excess of 85dB which may cause permanent hearing damage. Always verify that input signal levels are attenuated before powering on the speaker.

## 3.0 Inputs & Controls

### 1. [INPUT] XLR

Connector is designed to receive analog balanced line level audio signals from sources such as preamplifiers, sound cards, monitor controllers and mixing consoles. Pin 1 is tied to chassis ground. Pins 2 & 3 are fully floating differential inputs. Pin 3 must be referenced to ground for single-ended input signals. The analog signal is converted to 24bit/192kHz digital audio via a precision, ultra-high-fidelity analog to digital converter section inside the Footprint01.

### 2. [LEVEL]

Eight position rotary switch adjusts the loudness in precise increments ( +3dB, 0, -1, -2, -3, -5, -7 and -9dB. ) The 0dB setting corresponds to a sensitivity of 90dB at 1 meter distance using a -15dBv input signal.

### 3. [MEME IN]

3.5mm stereo phone jack for connection from MEME™ Selector Switch. See Section 9 for MEME™ settings and connection details. The default setting with no switch connected is Flat.

### 4. [MEME THRU]

3.5mm stereo phone jack for daisy chain connection to MEME IN of another Barefoot monitor. See Section 9 for MEME™ settings and connection details.

### 5. [FACTORY CALIBRATION]

The universal serial bus connector is for factory adjustments and calibrations. This connector is NOT an audio input.

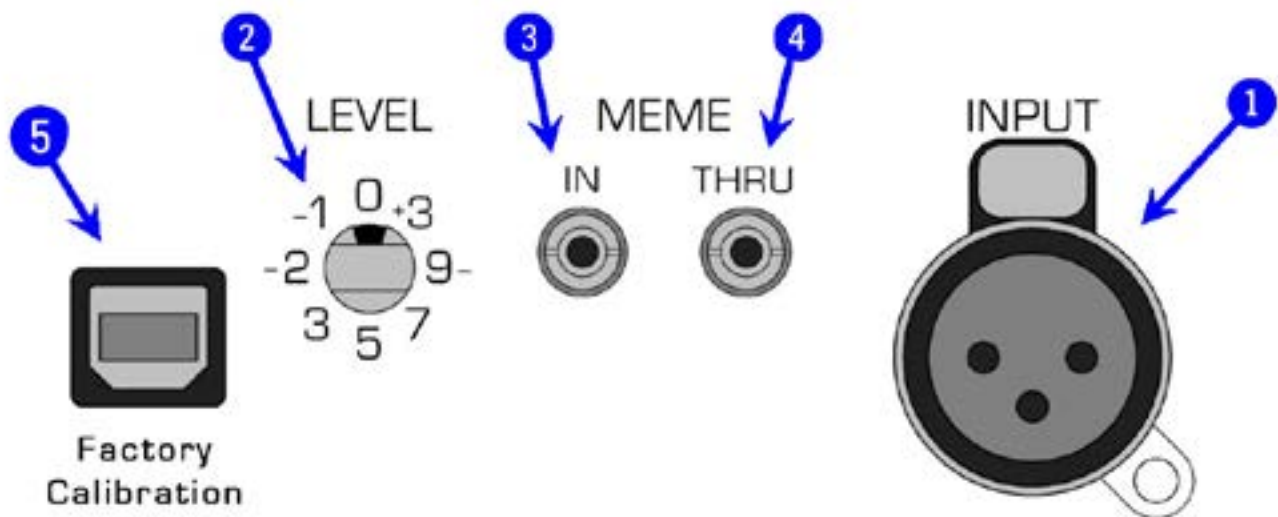

## 4.0 Startup

1. Plug in the grounded mains power cable (see warnings on previous page for details) .
2. Plug in an analog balanced audio signals from a source such as a pre amplifier, sound card, monitor controller or mixing console to INPUT XLR connector. Ensure that the audio signal is fully attenuated.
3. Power on the speaker with the rocker switch located on the rear panel above the mains connector. The LED indicator on the front of the speaker will illuminate Red for a couple of seconds and then turn Aqua.
4. Turn up the audio signal and enjoy!

## 5.0 Limiters

### Peak Limiter

The Low and High frequency channels have individual Peak Limiters designed to protect each driver from high amplitude, short duration audio input signal spikes that might cause damage due to over excursion of the voice coil. These limiters are implemented digitally within the DSP in such a manner that they have zero effect on the audio signal below their thresholds. The front LED indicator light will flash RED when a Peak Limiter on any of the driver channels is triggered. The duration of such events is only a fraction of a second. Therefore, the LED flash may appear pink or orange as the eye naturally blends the normally aqua-blue color of the LED with the red.

### RMS Limiter

The Low and High frequency channels have individual RMS Limiters designed to protect each driver from long duration, high amplitude audio input signals that might cause thermal damage due to the voice coil. These limiters are implemented digitally within the DSP in such a manner that they have zero effect on the audio signal below their thresholds. The front LED indicator light will flash RED when an RMS Limiter on any of the driver channels is triggered.

**Caution:** Signals large enough to trigger any of the limiters can generate very high sound pressure levels that may result in permanent hearing damage.

### Over Current

In the event of a large audio input signal that might damage the amplifiers or power supply due to current overload, the power supply is designed to enter into Over Current protect mode. This state typically results from a large, broadband input signal burst that flat lines the limiters on all four channels simultaneously. While the fault persists the amplifier power rails shut down, the speaker goes quiet, and the front panel LED turns red. Once the audio input signal is turned down the speaker should reboot within a few seconds. If the speaker fails to reboot or the LED light goes out completely, disconnect the audio input cable and power cycle the speaker. Verify the signal level is attenuated before reconnecting audio input cable.

**Caution:** Signals that cause Over Current protection to trigger can generate very high sound pressure levels that may result in permanent hearing damage.

## 6.0 Signal Flow Diagram

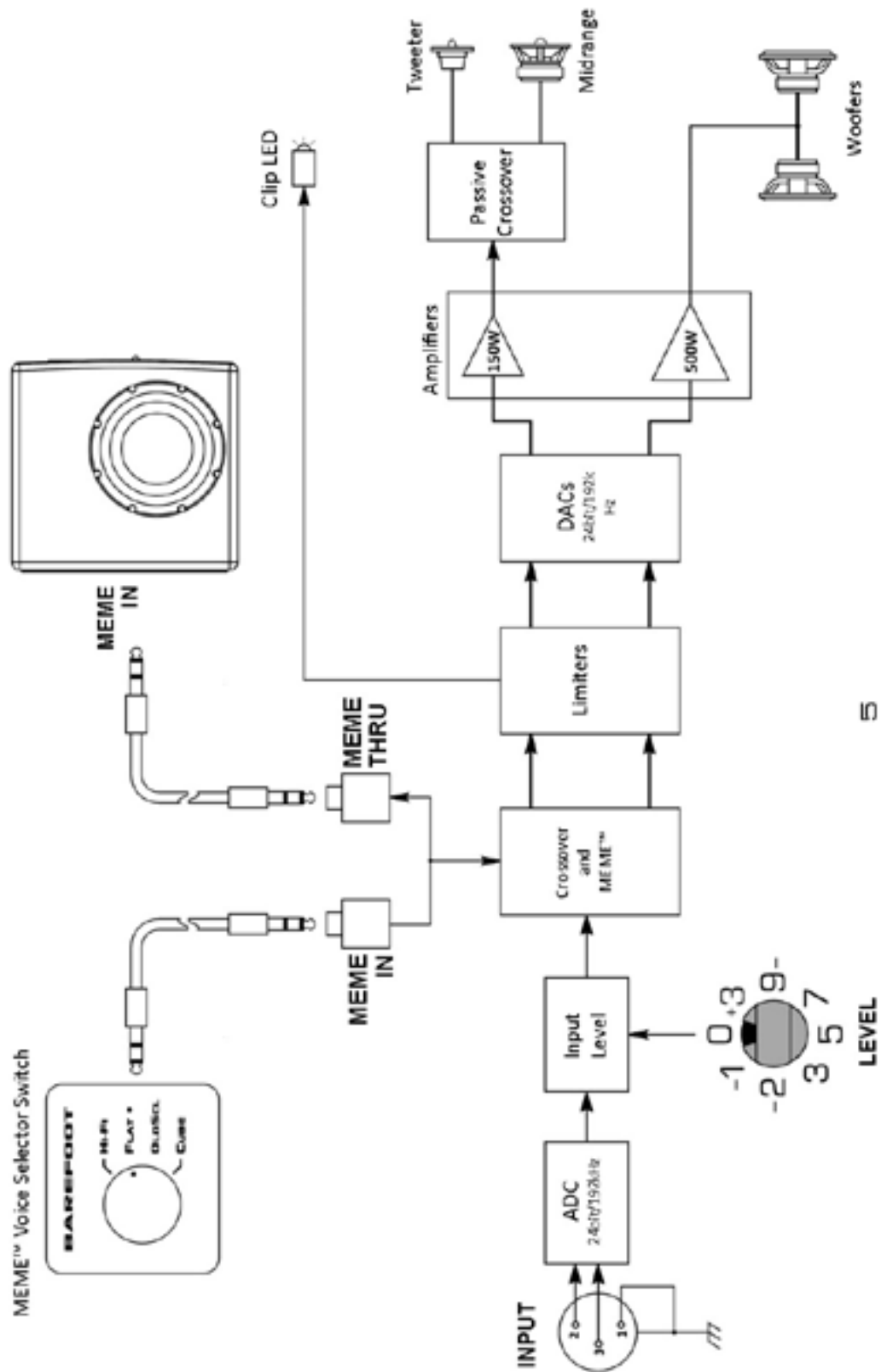



## 7.0 Positioning

The acoustic center of the Footprint02 is located at the LED indicator just above the tweeter. The Footprint02 is designed to work equally well as a nearfield or mid-field monitor. The minimum recommended listening distance is 3.0 feet (91 cm). This provides enough distance so the sound waves from the individual drivers can coalesce and the speaker sounds like a single source. While speaker positioning can often be dependent on the nature of the room, a good starting point is to create an equilateral triangle between the two speakers and the listening position. The speakers should be angled inward, so the tweeter axes aim towards the listener's ears, crossing a few inches behind the head.

A "typical" placement scenario might have the speakers positioned 1.5 feet (46 cm) from the front wall, the LEDs at ear level and the speakers and listening position forming an equilateral triangle with 4.0 feet (120 cm) sides. However, every room has its unique characteristics. Therefore, the optimal listening distances, speaker height and distances from walls are matters for experimentation. The Footprint02 is well equipped to work at a variety of listening distances.

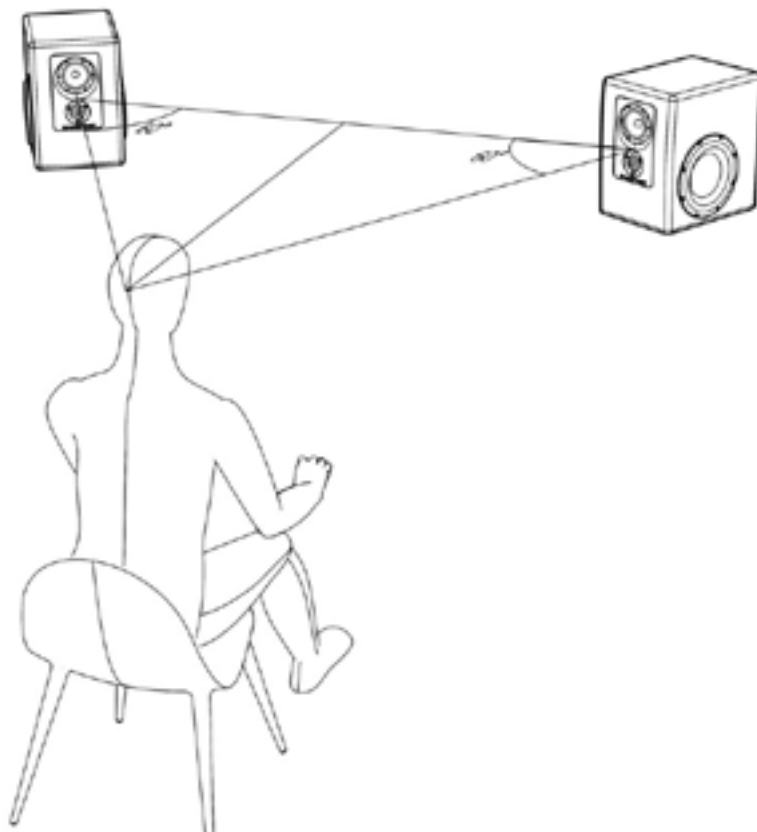

## 7.1 Widening the Stereo Field

We generally recommend angling the speaker axes in towards the listening position to create an equilateral triangle as described above. This yields the most accurate high frequency response and the sharpest stereo image at the center listening position. In some cases, however, the listener might change positions frequently. Or there might be multiple listeners. In such situations it may be desirable to have a wider and less focused stereo field which provides better coverage over a range of listening positions. This can be achieved by aiming the speaker axes more forward such that the axes cross further behind the center listening position. The figure below illustrates the general principle and is not meant to be an exact measure of speaker angles or optimal listening positions.

Since the Footprint02 has such wide off-axis dispersion, the horizontal angle relative to the listener can be

changed by up to 10 degrees with less than 1 dB variance in the frequency response across the audible spectrum. Angling the speakers forward in this manner will somewhat defocus the center stereo image while providing generally better imaging over a range of listening positions. For some users this may be an acceptable compromise.

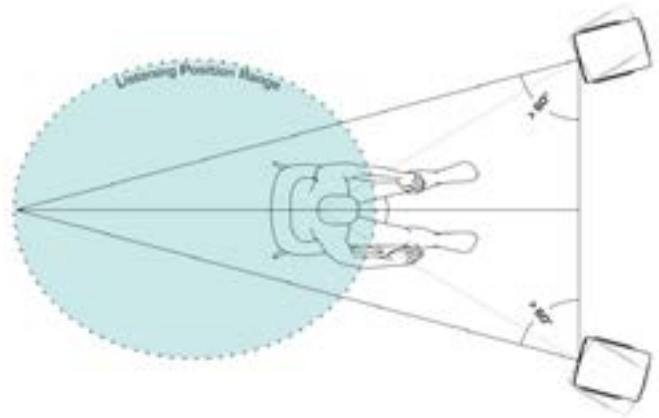

## 7.2 Cooling

While the amplifier modules that drive the Footprint02 are very efficient, the speaker still generates a significant amount of heat that must be dissipated. This heat is transmitted to the air via convection from the rear amplifier plate. In order to ensure proper airflow, a minimum of 2.0 inches (51 mm) clearance should be maintained between the speaker and any large obstructions like walls. An ambient room temperature below 30°C (85°F) should be maintained. Over-temperature may cause the speaker to overheat and shut down.

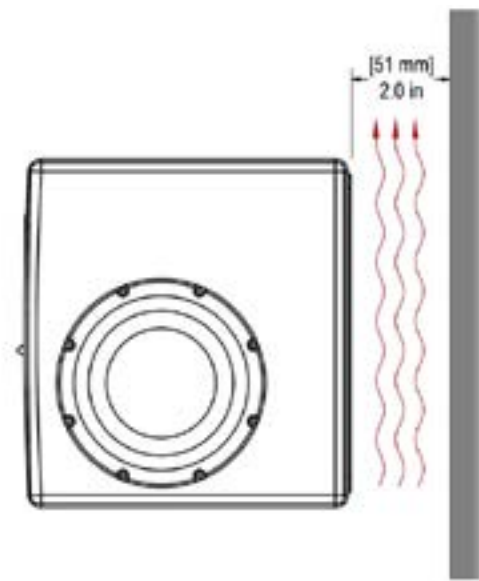

## 8.0 Maintenance

Exterior surfaces of this product may be cleaned using a non-abrasive lint-free cloth lightly damped with water. Disconnect the mains power cable when cleaning to avoid risk of electric shock. Do not use alcohol-based cleaners.

Driver active surfaces such as diaphragms and surrounds may be cleaned using dry soft bristle brushes. Driver diaphragms are very delicate and easily damaged. So, proceed with great care. Clean new sable artist brushes

or cosmetic brushes work well for this task. Gently brush dust away from the surface starting at the center of the driver diaphragm and moving radially outward. Avoid applying inward pressure to the driver diaphragm.

Repairs, maintenance, or other servicing of this product when its interior compartment is exposed should only be performed under specific advice from Barefoot Sound by a qualified technician or by the Barefoot Service Center. There are no user-serviceable parts inside this product.

---

## 8.1 Technical Support and Service

Your Barefoot authorized dealer/distributor is usually the best resource for technical support regarding your specific application. You can also contact Barefoot Sound directly:

[service@barefootsound.com](mailto:service@barefootsound.com)

To obtain repair service please refer to Warranty Section in this manual.

## 9.0 MEME™ (Multi Emphasis Monitor Emulation)

Barefoot MEME (pronounced “meam” like “team”) technology allows you to box up your secondary reference monitors for good. Despite the numerous advantages of high-resolution monitors like the Footprint01, many engineers still rely on their NS10s and mix cubes as secondary references. These speakers have long traditions and people find them familiar and useful for focusing in on certain aspects of their mix.

However, it’s also a fact that crowding your console with those extra boxes degrades the sound field of the primary reference monitors. Not to mention, these speakers are no longer manufactured, need amplifiers, require cable runs, and consume more studio space. MEME offers an elegant solution by emulating the sound and translation characteristics of those other classic monitors.



---

### 9.1 MEME Voices:

#### FLAT

Optimal setting for accuracy, transparency and outstanding translation. Setting has a flat frequency response and extremely fast transient response. This is the default voice when the MEME Selector Switch is not connected to the speaker.

#### HI-FI

While it does not emulate any one speaker in particular, this setting is indicative of “hi-fi” in the colloquial sense of the term. The midrange is a bit scooped and highs are a little accentuated. The bass response is altered to have less damping, yielding a hybrid character somewhere

between the fast, tight, articulate sound of a sealed cabinet and the slower, fatter sound of a ported speaker. The result is a sweeter more forgiving sonic character.

#### OLDSCL

This setting emulates the frequency, phase and transient response of the NS10M.

#### CUBE

This setting emulates the frequency, phase and transient response of classic mix cubes.

## 9.2 MEME™ Voicing Frequency Responses:

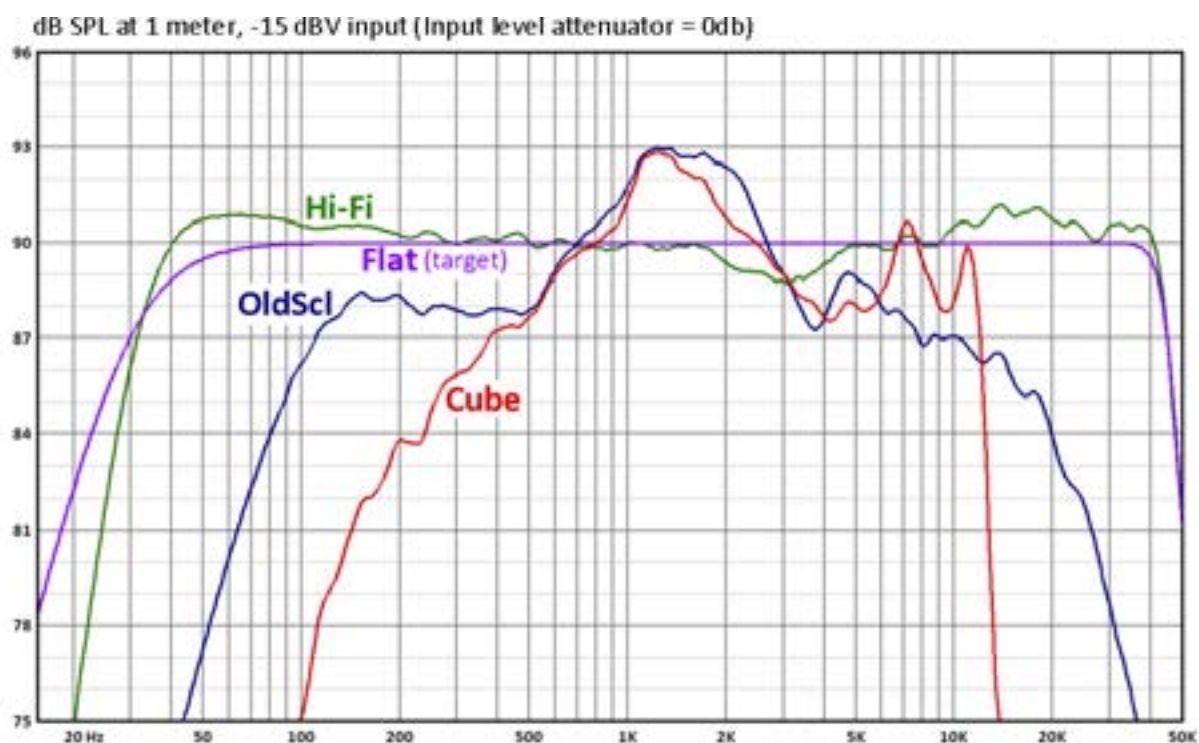

## 9.3 MEME™ Voice Selector Connection:

The MEME™ Voice Selector switch box is connected to the MEME IN jack of the speaker via any standard 3.5 mm stereo phone cable. The switchbox is passive and requires no batteries. Two or more speakers can be connected to the switch box by daisy chaining cables from the MEME OUT of one speaker to the MEME IN of the next speaker. The Footprint01 MEME IN and MEME OUT jacks are opto-isolated to prevent ground loops between devices.

Barefoot MicroMain Gen2 series monitors with MEME™ can also be connected to the MEME OUT of the Footprint01.

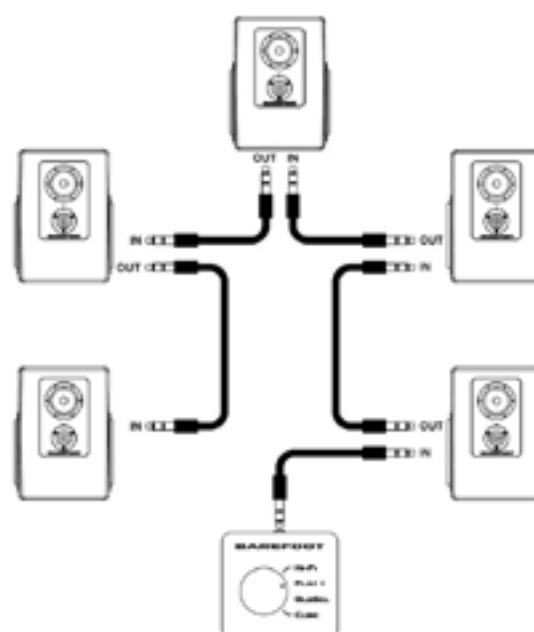

## 10.0 Dual-Force™ Technology

Cabinet vibrations are a significant source of distortion and coloration in most loudspeakers. The primary mechanism that generates cabinet vibrations is simple Newtonian action and reaction. As the driver motor (magnet and voice coil) forces the cone to move back and forth in order to generate sound, the cone exerts an equal and opposite force on the motor. This force is transmitted through the driver frame to the cabinet, vibrating the cabinet walls and coloring the sound emitted by the cone. This effect is most especially prevalent in the low frequency drivers where the cone motion is greatest.

While, the Footprint02 is built with a well braced cabinet, we also tackle the problem at its source by eliminating vibrations before they even begin. This is achieved through our innovative force cancellation

design. The low frequency drivers are mounted on opposing sides of the cabinet and their motors are locked together. As the cones are driven in and out in opposite directions the forces exerted on the motors cancel one another. The vibrations never make it to the cabinet because they are not allowed to develop in the first place.

This layout has further benefits. Since the drivers are locked together, the motors and frames function as a massive internal metal cabinet bracing. And because the wavelengths generated by the woofers are much larger than the speaker cabinet dimensions, the drivers radiate as if they were a single point source.

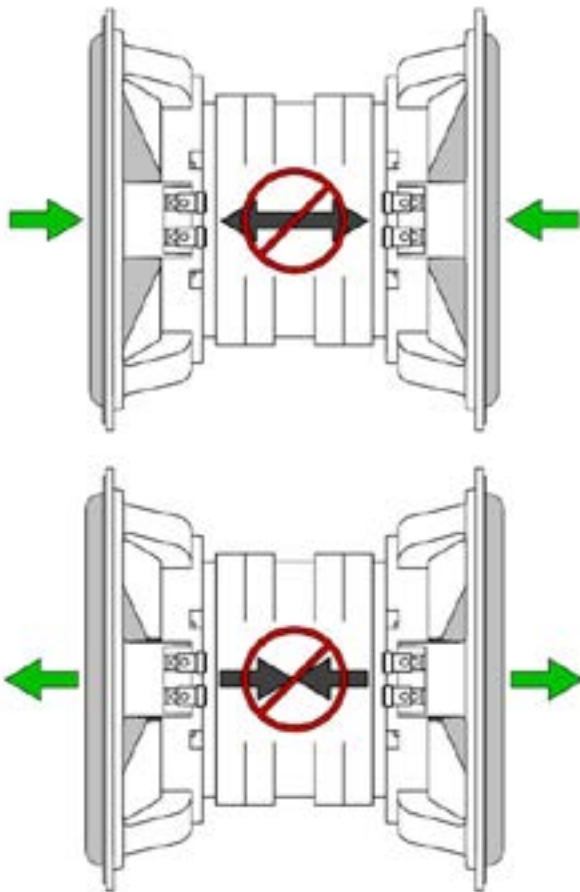

## 12.0 Specifications

<b>Description</b>	3-way active monitor with MEME™ voice emulation
<b>Controls</b>	Input level stepped attenuator, MEME voice select
<b>Input Impedance</b>	Balanced XLR, 50k Ohm Impedance
<b>Sensitivity</b>	90dB @ 1 meter with -15dBV input signal (Level control set to 0dB)
<b>Frequency Response</b>	42Hz – 45kHz (±3dB), 52Hz – 40kHz (±1dB)
<b>Bass Response</b>	-3 dB @ 36Hz, Q = 0.707 Slope = 18 dB/octave
<b>Cabinet</b>	13 liters total internal volume, Sealed woofer and midrange enclosures, Machined aluminum baffle plate, Polyurethane acoustic damping throughout
<b>Crossover Frequencies</b>	180 / 3600 Hz (Passive crossover between Midrange and Tweeter)
<b>Tweeter</b>	1" ring radiator, Low distortion motor, Rear waveguide chamber
<b>Midrange</b>	4.0" aluminum cone, Aluminum phase plug, Low distortion motor, +/- 3.5 mm linear excursion
<b>Woofers</b>	6.5" paper cone, +/- 8.2 mm linear excursion
<b>High Frequency Amplifier:</b>	150W
<b>Low Frequency Amplifier</b>	200W
<b>AC Power Input</b>	85 VAC to 265 VAC
<b>Power Consumption</b>	Idle: 2W, Maximum: 320W
<b>Weight</b>	Speaker: 27.9 lbs each (12.66 kg) Shipping: 33.6 lbs each (15.25 kg)
<b>Dimensions HxWxD</b>	12.12 x 8.7 x 13.0 inches (308 x 222 x 330 mm)

## 13.0 Dimensions inches [mm]

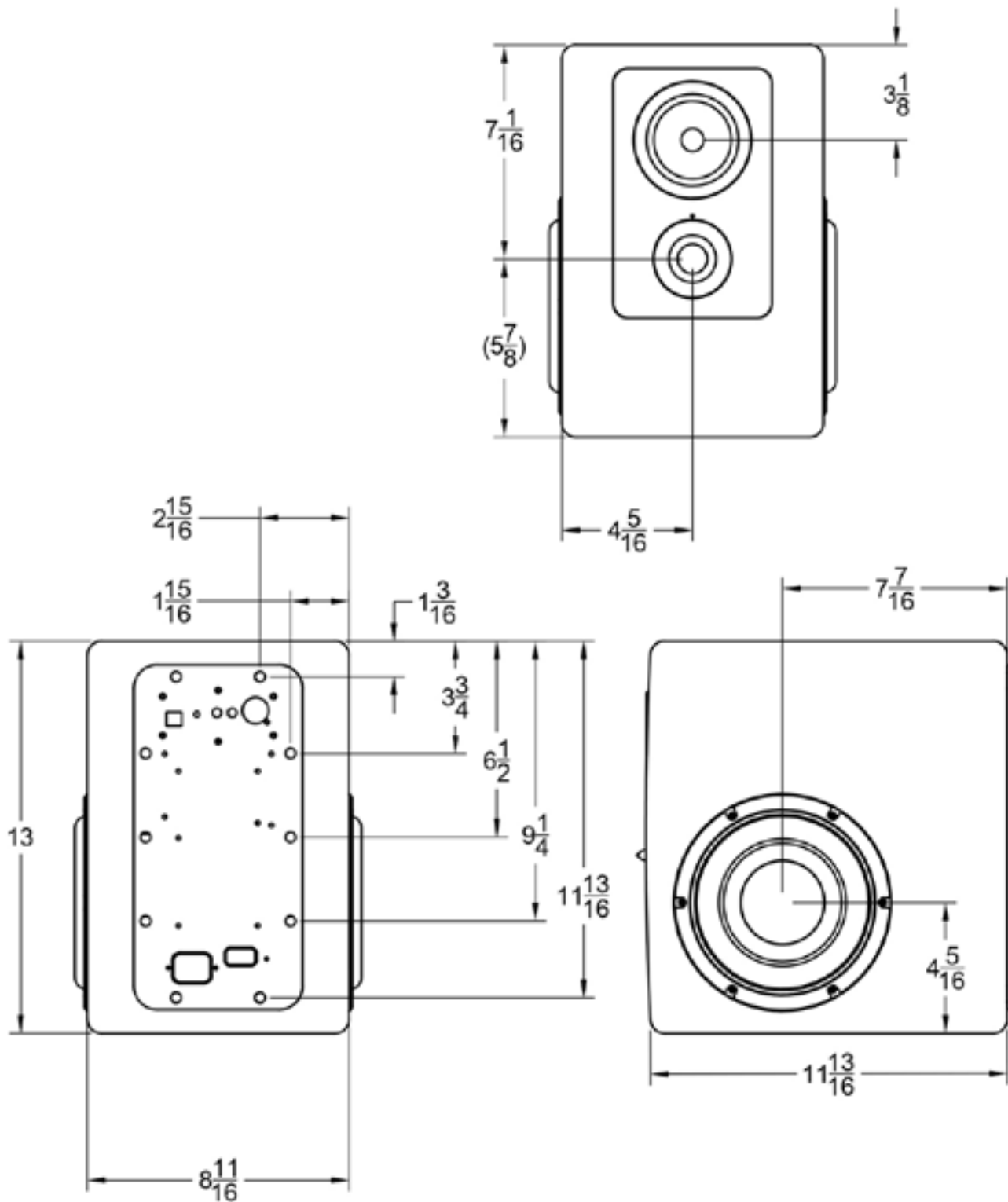



## 14.0 Limited Warranty

BAREFOOT SOUND warrants electronic components and cabinetry for a period of three (3) years against manufacturing defects, covering parts and labor for necessary repairs. Moving speaker components such as tweeters, midranges and woofers are warranted for a period of one (1) year against manufacturing defects.

Shipping fees incurred from returns for under-warranty service in the first 30-days will be paid by BAREFOOT SOUND. All shipping fees both to and from BAREFOOT SOUND following this 30-day period must be paid by the customer. All returns, both during and following the 30-day period, must be affected via the Procedures for Obtaining Warranty Service described below.

BAREFOOT SOUND makes no other warranty, either express or implied, including but not limited to implied warranties of merchantability, fitness for a particular purpose, or conformity to any representation or description, with respect to this product other than as set forth below. BAREFOOT SOUND makes no warranty or

representation, either express or implied, with respect to any other manufacturer's product or documentation, its quality, performance, merchantability, fitness for a particular purpose, or conformity to any representation or description.

Except as provided below, BAREFOOT SOUND is not liable for any loss, cost, expense, inconvenience or damage that may result from use or inability to use the product. Under no circumstances shall BAREFOOT SOUND be liable for any loss, cost, expense, inconvenience or damage exceeding the purchase price of the product.

The warranty and remedies set forth below are exclusive and in lieu of all others, oral or written, expressed or implied. No reseller, agent or employee is authorized to make any modification, extension or addition to this warranty.

---

## 14.1 Warranty Conditions

The above Limited Warranty is subject to the following conditions:

This warranty covers only normal use of the product. BAREFOOT SOUND shall not be liable under this warranty if any damage or defect results from (i) misuse, abuse, neglect, improper shipping or installation; (ii) disasters such as fire, flood, lightning or improper electric current; or (iii) repairs, service or alteration by anyone other than an authorized BAREFOOT SOUND representative; (iv) damages incurred through incorrect connection or handling, abnormal conditions, high humidity, deliberate abuse, power surges, water spills, or any other accidents.

You must retain your bill of sale or other proof of purchase to receive warranty service.

No warranty extension will be granted for any replacement part(s) furnished to the purchaser in fulfillment of this warranty.

To return a defective product, please contact our Customer Service Department at [service@barefoot-sound.com](mailto:service@barefoot-sound.com) for a Return Merchandise Authorization (RMA) number and follow the Return of Products Instructions below. The RMA is valid for 10 days from date of issuance. Returns will not be accepted without an RMA.

## 14.2 Procedures for Obtaining Warranty Service

RMA (Returning Merchandise Authorization) Policy:

If repairs are required, the customer must obtain a RMA number and provide proof of purchase. RMA and services are rendered by BAREFOOT SOUND only. Any shipping costs after 30 days (starting from the original date of purchase) on any item returned for repair is the customers' responsibility. All returned parts must have a RMA number written clearly on the outside of the package along with a letter detailing the problems and a copy of the original proof of purchase. No COD packages will be accepted. No package will be accepted without a RMA number written on the outside of the package.

1. If the product must be repaired, a RMA number (Return Merchandise Authorization Number) will be issued for shipment to our repair department. Please follow the instructions given by BAREFOOT SOUND technical support staff to ship your product. BAREFOOT SOUND will not accept any shipments without a RMA number.
2. Pack the product in its original box or a well-protected box, as outlined by BAREFOOT SOUND Customer Service. BAREFOOT SOUND will not be responsible for shipping damage/loss of any product not shipped in its original packaging. BAREFOOT SOUND will not be responsible for shipping damage/loss of any product outside the original 30-day paid service period. It is very important that you write the RMA number clearly on the outside of the package. Ship the product with a

copy of your bill of sale or other proof of purchase, your name, address, phone number, email address, description of the problem(s), and the RMA number you have obtained to the address provided to you by BAREFOOT SOUND Customer Service.

3. Upon receiving the product, BAREFOOT SOUND will repair or replace your product (at BAREFOOT SOUND's discretion) and will ship it back to you within 2 weeks (dependent on parts availability) via FedEx.
4. Cross-exchange (Parts only): You will need to provide a valid credit card number as a deposit guarantee when the RMA number is issued. Once approval has been obtained on your credit card, the part(s) will be shipped FedEx. You will need to ship defective part(s) back to BAREFOOT SOUND within 15 days to avoid charges to your credit card. If such charges are incurred, the shipped part(s) will be billed at the then current price.
5. BAREFOOT SOUND will pay for shipping to and from the customer only within the first thirty days following the original product ship date. Following this 30-day period all shipping fees both for under warranty and post warranty repairs are the sole responsibility of the customer. The customer also assumes full liability for losses or damages resulting from shipping as well as all responsibility to pursue remuneration for such issues with their selected carrier.

## 14.3 Post Warranty Repair

BAREFOOT SOUND accepts no liability for problems caused by after-market software or hardware modifications or additions. BAREFOOT SOUND is not responsible for any loss of work ("down time") caused by a product requiring service. This warranty is null and void if the defect or malfunction was due to damage resulting from operation not within manufacturer specifications. It will

also be null and void if there are indications of misuse and/or abuse. BAREFOOT SOUND has the option of voiding the warranty if anyone other than an BAREFOOT SOUND technician attempts to service the product. BAREFOOT SOUND will not warrant any problems arising from an act of God (lighting, flooding, tornado, etc.), electrical spikes or surges, or problems arising out of hardware, software, or additional devices added to

complement any product manufactured by BAREFOOT SOUND. Under no circumstances will BAREFOOT SOUND be responsible for any refund or remuneration exceeding the original purchase price of the product less any shipping fees. BAREFOOT SOUND will not be held responsible for typographical errors on sales receipts,

repair tickets, or on our website. BAREFOOT SOUND makes every effort to make sure all information on our website is correct.

---

## 14.4 Warranty Exclusions

BAREFOOT SOUND accepts no liability for problems caused by after-market software or hardware modifications or additions. BAREFOOT SOUND is not responsible for any loss of work ("down time") caused by a product requiring service. This warranty is null and void if the defect or malfunction was due to damage resulting from operation not within manufacturer specifications. It will also be null and void if there are indications of misuse and/or abuse. BAREFOOT SOUND has the option of voiding the warranty if anyone other than an BAREFOOT SOUND technician attempts to service the product. BAREFOOT SOUND will not warrant any problems

arising from an act of God (lighting, flooding, tornado, etc.), electrical spikes or surges, or problems arising out of hardware, software, or additional devices added to complement any product manufactured by BAREFOOT SOUND. Under no circumstances will BAREFOOT SOUND be responsible for any refund or remuneration exceeding the original purchase price of the product less any shipping fees. BAREFOOT SOUND will not be held responsible for typographical errors on sales receipts, repair tickets, or on our website. BAREFOOT SOUND makes every effort to make sure all information on our website is correct.

## 14.5 Service Request

In order to serve you better, please complete the service request form in the following link for your Barefoot Sound studio monitors. Once submitted and reviewed, a service representative will contact you.

LINK

<https://barefootsound.com/service-request/>

**BAREFOOT**

**Barefoot Sound LLC**

[barefootsound.com](http://barefootsound.com)



## PRODUCT REGISTRATION

Please complete the product registration form for your Barefoot Sound studio monitors to be registered for warranty and product updates.

[CLICK HERE TO REGISTER NOW](#)



## PROTECT YOUR BAREFOOT MONITORS

We will keep the model number and date of purchase of your new Barefoot Sound product on file to help you refer to this information in the event of an insurance claim such as loss or theft.