



## Transformer

Harmonic generator & color box



### Key Features:

- Transformer saturation circuit that adds low-end harmonics and a low-end bump
  - Passive saturation circuit that adds a lot of odd and even harmonics
- Active germanium stage with a vintage sound and a mix of harmonics
  - Class-A stage with a pleasant British 70's sound
- M/S function for separate processing of the mid and side channels
  - Detent potentiometers for easier recall

The Transformer is a recording and mixing tool that transform your sound by using several different harmonic stages. The unit is divided into two sections, a harmonic generating section and a transformer coupled class-A stage with a punchy, vintage tone.

If you're working mostly in the box this is the perfect tool to add some analog warmth, punch and color to your sound/mix.

The first section contains three different harmonic stages; a transformer saturation stage, a passive saturation/clipping stage and an active germanium circuit.

These three stages does not only generate different kinds of harmonics, they also shape the tone curve in different ways.

With a blend function you can blend in the desired amount of harmonics. You can also choose to process the mid and side channels separately by activating the M/S function.

The second section is a selectable vintage transformer coupled class-A stage which also has a HF boost function.

## TX Drive

TX Drive is the first harmonics stage which is a transformer saturation circuit. With a single control you can vary the amount of transformer saturation and still keep the level constant. The circuit generates around 1% of harmonics (distortion) in the low-end and a gentle amount of higher harmonics. It also adds a 2dB bump in the low-end around 30Hz. By turning the drive control the bump level and higher harmonics decreases, the low-end harmonics stays around 1%.

## Gain

The TX drive is followed by a gain control so you can drive the following Sat and Ge stages harder for more harmonics.

## Sat

The second stage is a passive saturation circuit which adds a lot of odd harmonics and by engaging the Even switch it also adds even harmonics. The harmonic amount depends on how hard the stage is driven.

## Ge

The third stage is an active germanium stage that adds more even than odd harmonics. It has a pleasant vintage sound with it's mix of harmonics and a soft high-end. Like the previous stage the amount of harmonics depend on how hard it's driven.

## Output trim

The Sat and Ge stages are followed by an output trim to fine adjust the level before it enters the blend control.

## Blend

With the Blend control you can blend the harmonics stages signal with the dry signal.

## M/S

An M/S function is provided so you can process the mid and side channels separately with different harmonic circuits. As an example you can use the TX drive on the mid channel for more low-end harmonics and the Sat and Ge stages for more harmonics on the side channel. The class-A stage can't be used in M/S as it's placed after the M/S encoder/decoder!

## Class-A

The blend control and M/S function are followed by a selectable transformer coupled class-A stage that adds a fat and punchy sound with mid-character and a silky top end associated with the British class-A from the early 70's.

This stage also has a HF boost function that adds a small amount of air to the sound when activated. **The Class-A stage is also bypassed when the channel is bypassed with the in/out switch.**

**Frequency and harmonic distortion graphs** are available on TK Audio webpage.

<https://tkaudio.se/transformer>



### Specifications:

Input impedance: 20kohm

Max input level: +26dBu

Max output level: +26dBu

S/N ratio @ 0dBu: 89dB, depends on which stages that are activated

Dynamic range: 115dB

Power consumption: 13VA

Power requirement: 115v or 230v internally selectable

### Features:

TX Drive control

TX Drive in/out

Gain, up to +20dB

Channel in/out

Saturation in/out

Even in/out (adds even harmonics to the saturation circuit)

Output trim, -20dB to 0dB

Ge stage in/out

Class-A in/out

HF in/out, (class-A stage HF boost)

Blend control, between harmonics stages and dry signal

M/S in/out

All switches are illuminated

Detent potentiometers with 41 clicks

*Specifications and components may be changed or updated without further notice.*

### Two ground jumpers are provided inside the unit.

Jumper 1 (J4) disconnects the audio ground from the chassis.

Jumper 2 disconnects pin 1 on all four XLR connectors.

If you experience hum or a higher noise level than normal, try remove the J4 jumper!



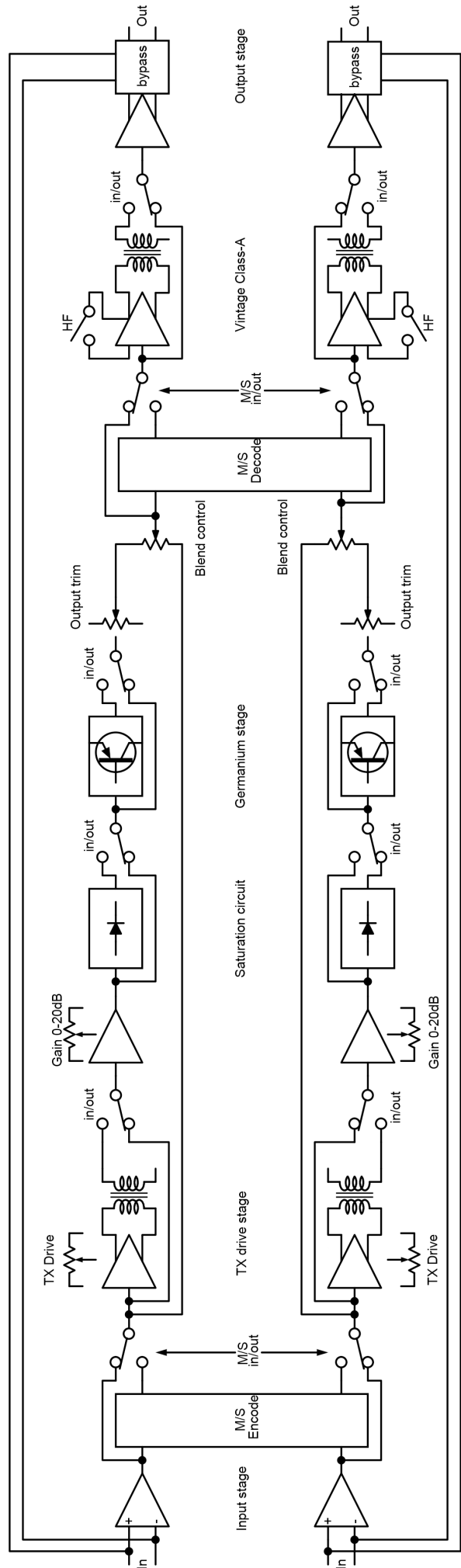
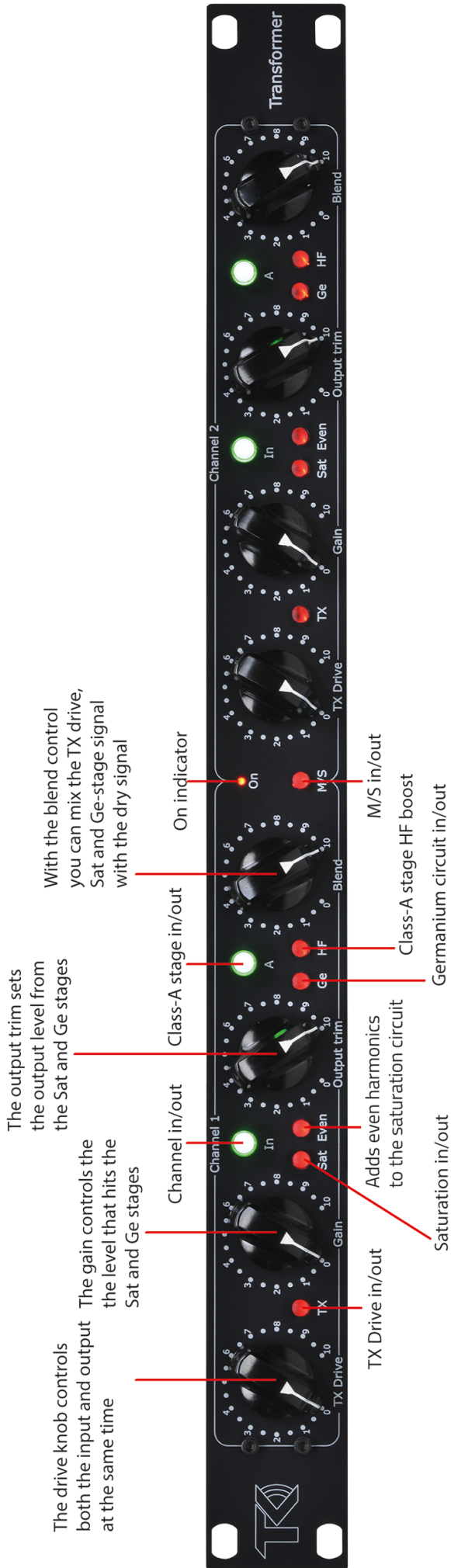

## EU - Declaration of conformity / Överensstämmelseintyg

### Product

Transformer  
115v - 200mA, anti surge fuse (slow)  
230v - 100mA, anti surge fuse (slow)

### Manufacturer / Tillverkare

Musikverkstan i Halmstad AB / TK Audio  
Falkenbergsgatan 10  
30233 Halmstad  
Sweden

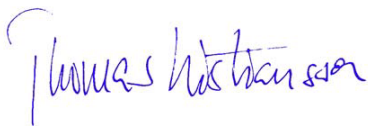

Thomas Kristiansson, CEO  
Halmstad, January 2025

### Declaration of conformity

I declare under my sole responsibility that this product, to which this declaration relates, is in conformity with the following standards:  
EN55013, EN55020:2002, EN61000-3-2, EN61000-4-2 and EN60065  
Following the provision of 73/23/EEC, 89/336/EEC and 93/68/EEC.

### Överensstämmelseintyg

Härmed intygas helt på eget ansvar att denna produkt, vilket detta intyg avser, uppfyller följande standarder:  
EN55013, EN55020:2002, EN61000-3-2, EN61000-4-2 och EN60065  
Följer reglerna 73/23/EEC, 89/336/EEC och 93/68/EEC